

McMenon A6 Glass Variable Area Flowmeter

Long-term reliable performance flowmeters with low cost-of-ownership



High strength stainless steel body

The body is corrosion resistant stainless steel, rigidly constructed to maintain tube alignment and resist pipe strain.

'SNAP-IN' tube construction

Minimizes the downtime needed to clean the meter tube or to change the meter range.

Polycarbonate operator protection shield

Safety tested shield protects personnel from glass fragments in the rare event of accidental tube breakage.

Component flexibility

All parts for the three scale lengths except bodies, tubes and protector shields are interchangeable.

Internal backcheck

Restricts back flow and draining of process fluid when metering tube is removed.

Choice of operating position

The meter can be inverted and its tube reversed to change the control valve position from the inlet to the outlet.

Options of valve, DP regulator and alarms

Tailor your setup for optimal performance and safety.

ATEX-approved versions available both with and without alarms

II 2GD approval without alarms; II 2G approval with alarms.

Introduction

McMENON A6 Flowmeters are low capacity variable area flowmeters for both liquid and gas with an excellent selection of material and scale lengths in a single product family design. They provide optimum flexibility with a minimum number of components. The meter features a corrosion resistant, high strength stainless steel body, quick, easy snap-in tube construction and a safety tested operator protection shield.

A differential pressure regulator is available, which will maintain a constant flowrate of a liquid or gas even when there are pressure variations. It is supplied piped into the meter as an assembly, ready to use.

A constant liquid or gas flowrate is achieved by creating a constant pressure drop. Manually changing the needle valve setting on the flowmeter changes the flowrate value. The differential pressure regulator then maintains this constant flowrate even when the pressure varies.

However when metering gases their compressibility means that – although the supply pressure can change - the downstream pressure must be fixed, if the volume flowrate is to be held at the set value.

In addition, one or two inductive ring sensor alarms can be fitted to certain model variants. These enable High, Low or even High and Low flow trip points to be set and a solid state status signal transmitted. If external switching of signals is to be initiated by these sensors, additional amplifiers/relays should be used.

McMENON Variable Area flowmeters are ideal for applications such as the purging of control lines and instrument enclosures. Their use is easily extended into fluid sampling, liquid specific gravity, level measurement and similar services.

Specification

Measuring ranges

See measuring ranges on pages 3, 4 and 5

Rangeability

≤10:1

Scale design

% or direct reading scales

Dt/Df ratio scale, millimeters

Accuracy classes (VDE/VDI 3513)

5 in. scale length

1/4 in. & 1/8 in. tube diameter 2.5

3 in. scale length

All sizes 10

1 1/2 in. scale length

All sizes 10

Process temperature limits

Non-certified systems

Stainless steel fittings : 0 to 120 °C

Brass fittings : 0 to 95 °C

Option/Temp Class	Max permissible process temperature in °C		
	T6	T5	T4
A6xxx without ring sensors	75	90	120
A6xxx with ring sensors	40	40	40

Ambient temperature limits

A6xxx without ring sensors : 0 to 60 °C

A6xxx with ring sensors : 0 to 40 °C

Types of installation

In-line, front- & rear-panel-mounting Wall-mounting (regulator only)

Scale length (in.)	Material			
	Stainless steel		Brass	
	Fluid Temperature		Fluid Temperature	
	Max.	Design	Max.	Design
	120 °C (248 °F)	38 °C (100 °F)	95 °C (203 °F)	38 °C (100 °F)
1 1/2 to 3	1800 (18)	1800 (18)	1400 (14)	1800 (18)
5 to 10	1800 (18)	1800 (18)	1400 (14)	1800 (18)

Materials

Wetted Parts	Standard	Options
Measuring Tube	Borosilicate glass	–
1/8 in.	Glass (BG) Sapphire (SA) 316 Stainless Steel	Carboloy (CA) Tantalum (TA)
1/4 in.	Glass (CD) 316 Stainless Steel	Sapphire (SA) Carboloy (CA) Tantalum (TA)
Float Stop 5 in. tube 3 & 1 1/2 in. tube	PTFE 316 Stainless Steel	316 Stainless Steel
Fittings	Brass 316 S31 Stainless Steel	
DP Regulator	Brass 316 S31 Stainless Steel	– –
O-rings	Buna N Viton A	Ethylenepropylene Kalrez
Tube Adapter	Brass 316 Stainless Steel	–
Needle Valve	316 S31 Stainless Steel	–
Non -return Ball	PTFE	–
Other components		
Body	304 Stainless Steel	
Operator Protection Shield	Polycarbonate	

Connections

1/4 in. NPT or G1/4 internal thread, horizontal (rear facing) or vertical

Weights

	Without Regulator (kg)	With Regulator (kg)
Model A6131/41	0.45	1.6
Model A6132/42	0.65	1.8
Model A6133/43	0.80	2.0
Model A6134/44	0.45	1.6
Model A6135/45	0.45	1.6

Measuring Ranges – Models A6131/41

Measuring Tube	Float	Water		Air 0 °C 1013 mbar (cm ³ /min) (Q _n)		Min. diff. press. bar ^a	Alarm RC10 = 1 RC15 = 2	Measuring Tube/Float Combination ^c
		cm ³ /min	l/h	Q _n (cm ³ /min)	Q _n (l/h)			
FP- ¹ / ₈ -08-P-3/37	BG-18	0.4 to 4.4	0.02 to 0.26	20 to 360*	2 to 21	0.17	–	F1
	SA-18	0.5 to 8.5	0.04 to 0.5	20 to 500	2 to 30	0.18	–	F5
	SS-18	1 to 19*	0.1 to 1.1	50 to 850*	3 to 50	0.18	1	F6
	CA-18	2 to 34	0.1 to 2.0	50 to 1300	5 to 80	0.18	1	F2
FP- ¹ / ₈ -20-P-3/37	BG-18	2 to 28	0.1 to 1.7	100 to 1500	5 to 95*	0.21	–	F8
	SA-18	4 to 48*	0.2 to 2.9	200 to 2000	10 to 125	0.21	–	G1
	SS-18	5 to 90*	0.4 to 5.4*	200 to 3000*	10 to 180	0.21	1	G2
	CA-18	10 to 135	0.5 to 8.0	400 to 4000	20 to 260	0.21	1	F9
	TA-18	15 to 145	1 to 8.5	460 to 4600	27 to 270	0.21	–	H1
FP- ¹ / ₄ -15-P-3/37	CD-14	10 to 130	0.5 to 7.5	500 to 6500	20 to 380	0.35	–	N0
	SA-14	23 to 230	1.4 to 14	850 to 8500	52 to 520	0.35	–	N3
	SS-14	20 to 400	2 to 23.0	1000 to 12500	50 to 750	0.7	2	N6
	CA-14	40 to 580	2 to 34.0	1000 to 17000	100 to 1050	0.7	2	M3
FP- ¹ / ₄ -20-P-3/37	CD-14	20 to 220*	0.5 to 13.0*	500 to 9500	40 to 560	0.35	–	M4
	SA-14	40 to 400	2 to 22	1000 to 12500	70 to 750	0.35	–	M5
	SS-14	40 to 580*	2.0 to 34.0*	1000 to 18000	100 to 1100	0.7	2	M6
	CA-14	50 to 850	4 to 50.0	2000 to 25000	100 to 1500	0.7	2	N1
FP- ¹ / ₄ -41-G-3/37	CD-14	40 to 460	2 to 27.0	1000 to 19000	100 to 1150	0.7	–	N2
	SA-14	70 to 750	4 to 46	3000 to 27000	200 to 1600	0.7	–	N5
	SS-14	100 to 1200	5 to 75.0*	2000 to 38000	100 to 2300	0.7	2	N8
	CA-14 ^b	100 to 1800	10 to 105	4000 to 54000	200 to 3200	–	2	M9

- Notes.** a) Applies only with differential pressure regulator
 b) Not available with differential pressure regulator
 c) For ordering information only

* Direct reading scales as standard

Measuring Ranges – Models A6131/41 with Inductive Alarm Sensor (RC10/RC15)

Measuring Tube	Float	Water cm ³ /min	Air 0 °C 1013 mbar (cm ³ /min) (Q _n)	Minimum Differential Pressure (bar) ^a	Ring Sensor
FP- ¹ / ₈ -08-P-3/37	SS-18	2 to 19	100 to 850	0.18	RC10-14-N3-Y115614
FP- ¹ / ₈ -20-P-3/37	SS-18	10 to 90	400 to 3200	0.21	
FP- ¹ / ₄ -15-P-3/37	SS-14	40 to 400	1000 to 12500	0.7	RC15-14-N3-Y115615
	CA-14	80 to 580	2000 to 17000	1.5	
FP- ¹ / ₄ -20-P-3/37	SS-14	80 to 580	2000 to 18000	0.7	
	CA-14	100 to 850	4000 to 25000	1.5	
FP- ¹ / ₄ -41-G-3/37	SS-14	150 to 1200	6000 to 40000	0.7	
	CA-14	200 to 1800	8000 to 54000	Note ^b	

- Notes.** a) In conjunction with differential pressure regulator
 b) Not available with differential pressure regulator

Measuring Ranges – Models A6132/42

Measuring Tube Size	Measuring Tube No.	Float No.	Max. flow ^a		Alarm RC10 = 1 RC15 = 2	Float/ Measuring Tube Combination ^c
			Water cm ³ /min	Air 0 °C 1013 mbar (cm ³ /min) (Q _n)		
1/8 in.	FP-1/8-08-G-5/81 12 16 20 25	BG-18	6.1	373.6		H2
			13.9	696.3		H7
			22.6	1046.2		J2
			31.5	1426.6		J7
			43.7	1885.1		K2
	FP-1/8-08-G-5/81 12 16 20 25	SA-18	10.5	511.3		H4
			23.0	928.8		H0
			35.7	1384.7		J4
			48.5	1857.6		J9
			64.5	2454.0		K4
	FP-1/8-08-G-5/81 12 16 20 25	SS-18	20.5	804.4	1	H5
			39.5	1421.4	1	J0
			60.0	2092.8	1	J5
			81.0	2788.3	1	K0
			107.0	3629.1	1	K5
	FP-1/8-08-G-5/81 12 16 20 25	CA-18	33.6	1205.7	1	H3
			61.2	2089.4	1	H8
			90.6	3014.3	1	J3
			121.7	3997.8	1	J8
			159.7	5136.7	1	K3
FP-1/8-08-G-5/81 12 16 20 25	TA-18	36.5	1287.9		H6	
		66.0	2219.0		J1	
		97.5	3202.4		J6	
		130.0	4229.3		K1	
		171.5	5456.3		L1	
1/4 in.	FP-1/4-10-G-5/81 16 20 25	CD-14	78	3717		R4
			152	6742		S0
			206	8928		S6
			275	11479		T2
	FP-1/4-10-G-5/81 16 20 25	SA-14	134	5200		R5
			253	9245		S1
			337	12231		S7
			446	15650		T3
	FP-1/4-10-G-5/81 16 20 25	SS-14	228	7793	2	R6
			415	13672	2	S2
			547	17979	2	S8
			703	22900	2	T4
	FP-1/4-10-G-5/81 16 20 25	CA-14	346	10967	2	R3
			612	19227	2	R9
			805	25293	2	S5
			1036	32200	2	T1
	FP-1/4-10-G-5/81 16 20 25	TA-14	370	11704		R7
			660	20457		S3
			860	26703		S9
			1105	34276		T5
FP-1/4-40-G-6/81 FP-1/4-40-G-6/81 FP-1/4-40-G-6/81	SS-14	1500	45700	2	V0	
	CA-14	2050	64800	2	T7	
	TA-14	2200	67200		W1	

- Notes.**
- a) Maximum flow rates for other fluids can be calculated using our sizing software – contact MCMENON
 - b) Not available with differential pressure regulator
 - c) For ordering information only

Measuring Ranges – Models A6132/42 with Inductive Alarm Sensor (RC10/RC15)

Measuring Tube	Float	Max. Flow		Minimum Differential Pressure (bar) ^a	Ring Sensor
		Water cm ³ /min	Air 0 °C 1013 mbar (cm ³ /min) (Q _n)		
FP-1/8-08-G-5/81 12 16 20 25	SS-18	20.5 39.5 60.0 81.0 107.0	804.4 1421.4 2092.8 2788.3 3629.1	0.18	RC10-14-N3-Y115614
FP-1/4-10-G-5/81 16 20 25	SS-14	228 415 547 703	7793 13672 17979 22900	0.7	
FP-1/4-10-G-5/81 16 20 25	CA-14	346 612 805 1036	10967 19227 25293 32200	1.5	RC15-14-N3-Y115615
FP-1/4-40-G-6/281 40	SS-14 CA-14	1512 2180	48384 67580	0.7 ^b	

- Notes.** a) In conjunction with differential pressure regulator
b) Not available with differential pressure regulator

Measuring Ranges – Models A6133/43

Measuring Tube	Float	Max. Flow			
		Water		Air 0 °C 1013 mbar	
		cm ³ /min	l/h	cm ³ /min (Q _n)	l/h
FP-1/4-10-G-10	BG-14	10 to 95	0.8 to 5.6	400 to 4200	20 to 250
FP-1/4-10-G-10	CA-14	40 to 360	2 to 22	1500 to 11500	100 to 700
FP-1/4-40-G-10	BG-14	80 to 600	4 to 38	2000 to 26000	200 to 1600
FP-1/4-40-G-10	SS-14	150 to 1500*	10 to 90	6000 to 48000	200 to 2900
FP-1/4-40-G-10	CA-14	200 to 2200*	15 to 135	1000 to 70000	400 to 4000

*Not available with differential pressure regulator

Measuring Ranges – Models A6133/43 with Inductive Alarm Sensor (RC10/RC15)

Measuring Tube	Float	Max. Flow			
		Water		Air 0 ° C 1013 mbar	
		cm ³ /min	l/h	cm ³ /min (Q _n)	l/h
FP-1/4-10-G-10	CA-14	40 to 360	2 to 22	1500 to 11500	100 to 700
FP-1/4-40-G-10	SS-14	150 to 1500*	10 to 90	6000 to 48000	200 to 2900
FP-1/4-40-G-10	CA-14	200 to 2200*	15 to 135	1000 to 70000	400 to 4000

*Not available with differential pressure regulator

Measuring Ranges – Models A6134/44

Measuring Tube ^b	Float No.	Water cm ³ /min	Air 0 °C 1013 mbar (cm ³ /min) (Q _n)	Min. Required Differential Press bar ^a	Float/ Measuring Tube Combination ^d
Tube No.					
FP-1/8-21-P-1 1/2/19	BG-18	2.5 to 37.5	100 to 2000	0.21	E1
	SA-18	5.0 to 60.0	200 to 2600	0.21	E3
	SS-18	10 to 120.0	200 to 3800	0.21	E4
	CA-18	14 to 180	280 to 5600	0.21	E2
FP-1/4-28-P-1 1/2/19	SA-14	30 to 570	1300 to 19500	0.7	L2
	SS-14	50 to 850	2000 to 28000	0.7	L3
FP-1/4-41-P-1 1/2/19	SS-14 ^c	100 to 1600	2500 to 45000	-	M1
	CA-14 ^c	200 to 2200	5000 to 70000	-	L4

- Notes.**
- a) Applies only with built-in differential pressure regulator.
 - b) Only with % scale. Not available with differential pressure regulator.
 - c) Not available with differential pressure regulator.
 - d) For ordering information only.

Overall Dimensions

In-line and Front Panel-Mounting (Horizontal and Vertical connections)

Dimensions in mm (in.)

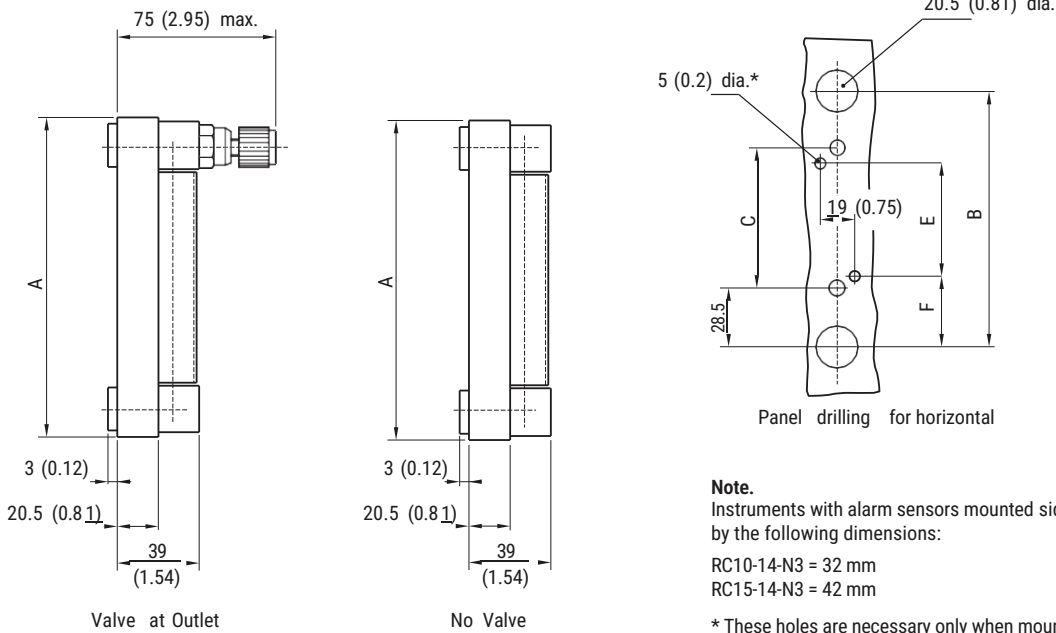
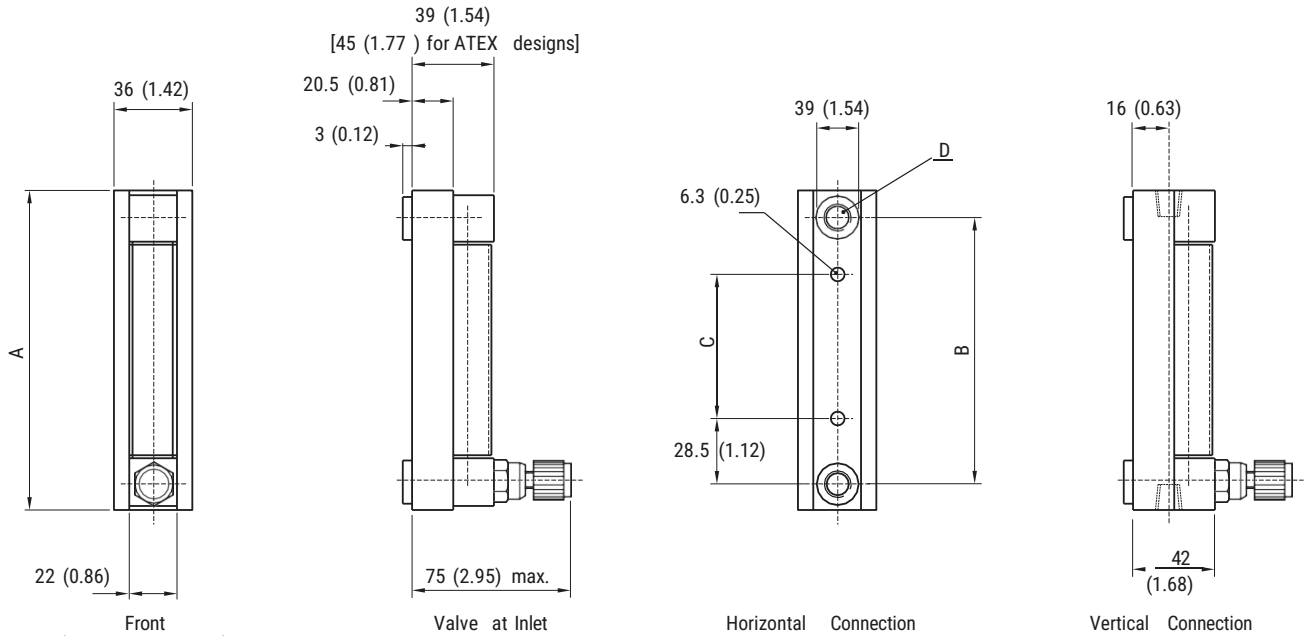

Note.
Instruments with alarm sensors mounted side-by-side should be separated by the following dimensions:
RC10-14-N3 = 32 mm
RC15-14-N3 = 42 mm

* These holes are necessary only when mounting using adapter plates

Dimensions

	D	F	E	C	B	A	Scale Length	Model No.
G 1/4	1/4 in. NPT	36.5	165	181	238	264	4/5 in.	A6x32/42
G 1/4	1/4 in. NPT	27.2	71	68	125	151	3 in.	A6x31/41
G 1/4	1/4 in. NPT	27.2	40	37	94	120	1 1/2 in.	A6x34/44
G 1/4	1/4 in. NPT	27.2	71	68	125	151	3 in.	A6x35/45

Variable Area Flowmeter with Regulator

Dimensions in mm (in.)

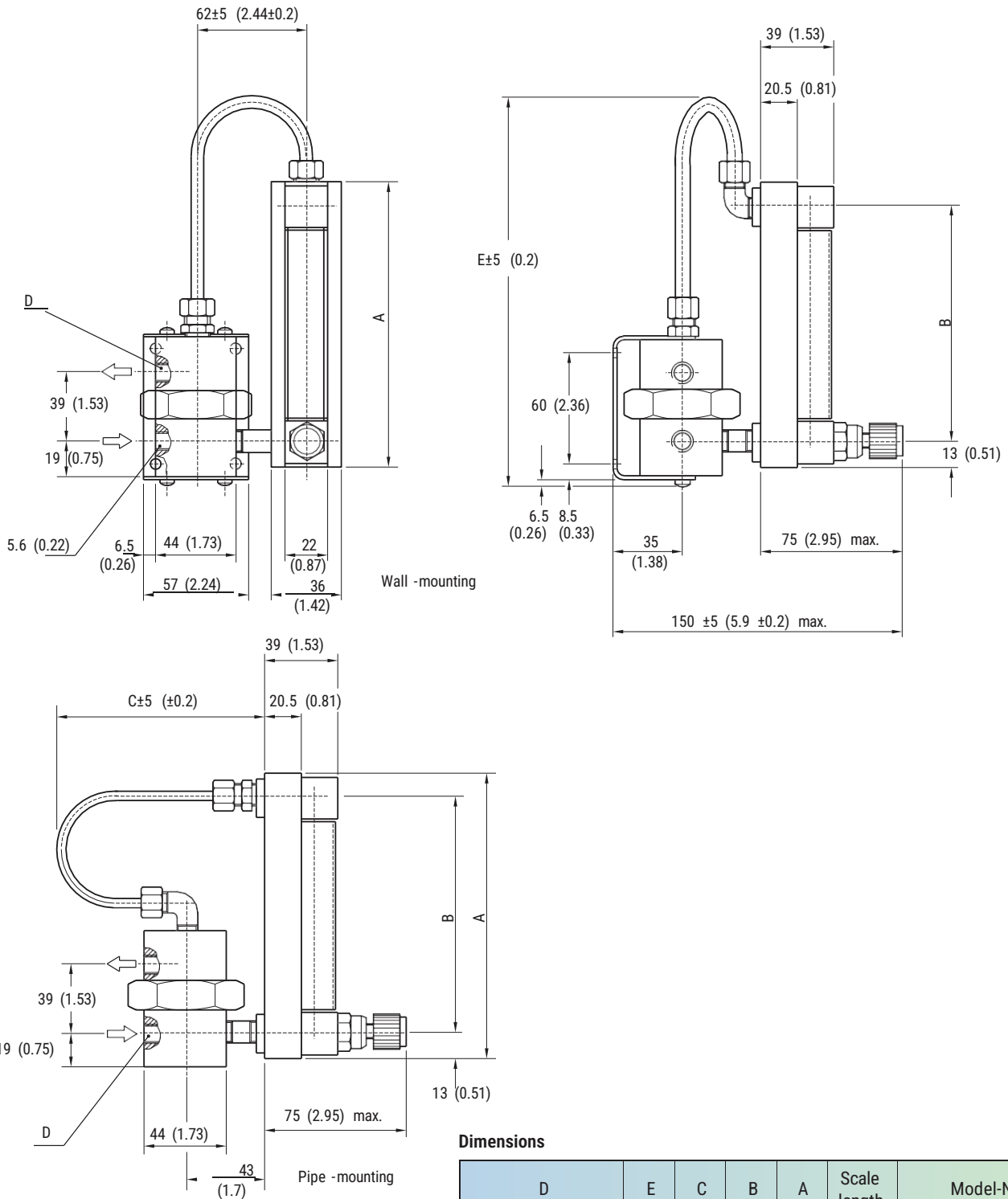

Dimensions

	D	E	C	B	A	Scale length	Model-No.
G 1/4	1/4 in. NPT	338	80	238	264	5 in.	A6122-53R_2110
G 1/4	1/4 in. NPT	225	108	125	151	3 in.	A6121-53R_2110
G 1/4	1/4 in. NPT	194	108	94	120	1 1/2 in.	A6124-53R_2110

Panel-Mounting (Horizontal connections)

Dimensions in mm (in.)

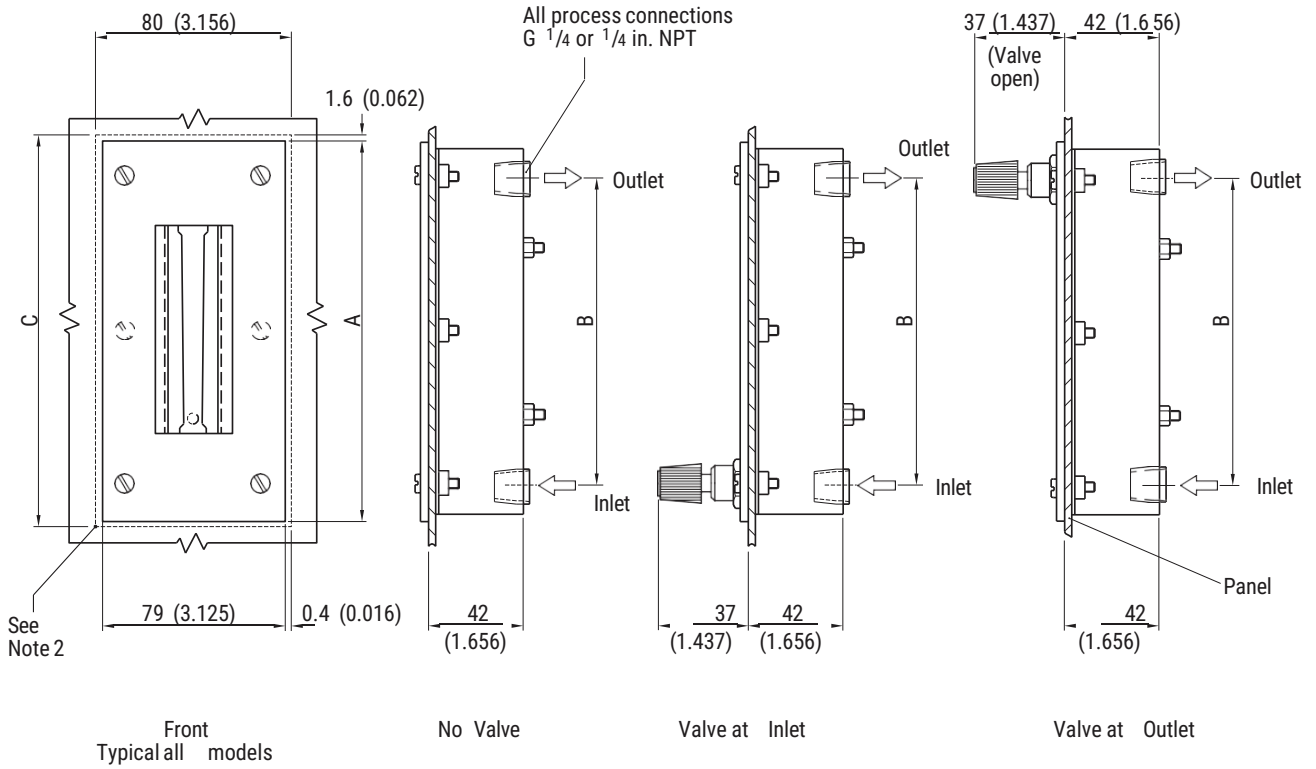

Dimensions

Nom. Scale Length		A		B		C	
in.	mm	in.	mm	in.	mm	in.	mm
1 1/2	38	4 ³¹ / ₃₂	126	3 ²³ / ₃₂	94	5 ³ / ₃₂	129
3	76	6 ³ / ₁₆	157	4 ¹⁵ / ₁₆	125	6 ⁵ / ₁₆	160
5	127	10 ⁵ / ₈	270	9 ³ / ₈	238	10 ³ / ₄	273
10	254	15 ¹ / ₁₆	383	13 ¹³ / ₁₆	351	15 ³ / ₁₆	386

Notes.

- 1) All dimensions are subject to a manufacturing tolerance of ± 3 mm (0.125), unless otherwise specified.
- 2) Dotted line indicates rear of panel clearance requirements.
- 3) Panel hardware for 8 (0.312) max. panel thickness.

Panel-Mounting with Differential Pressure Regulator

Dimensions in mm (in.)

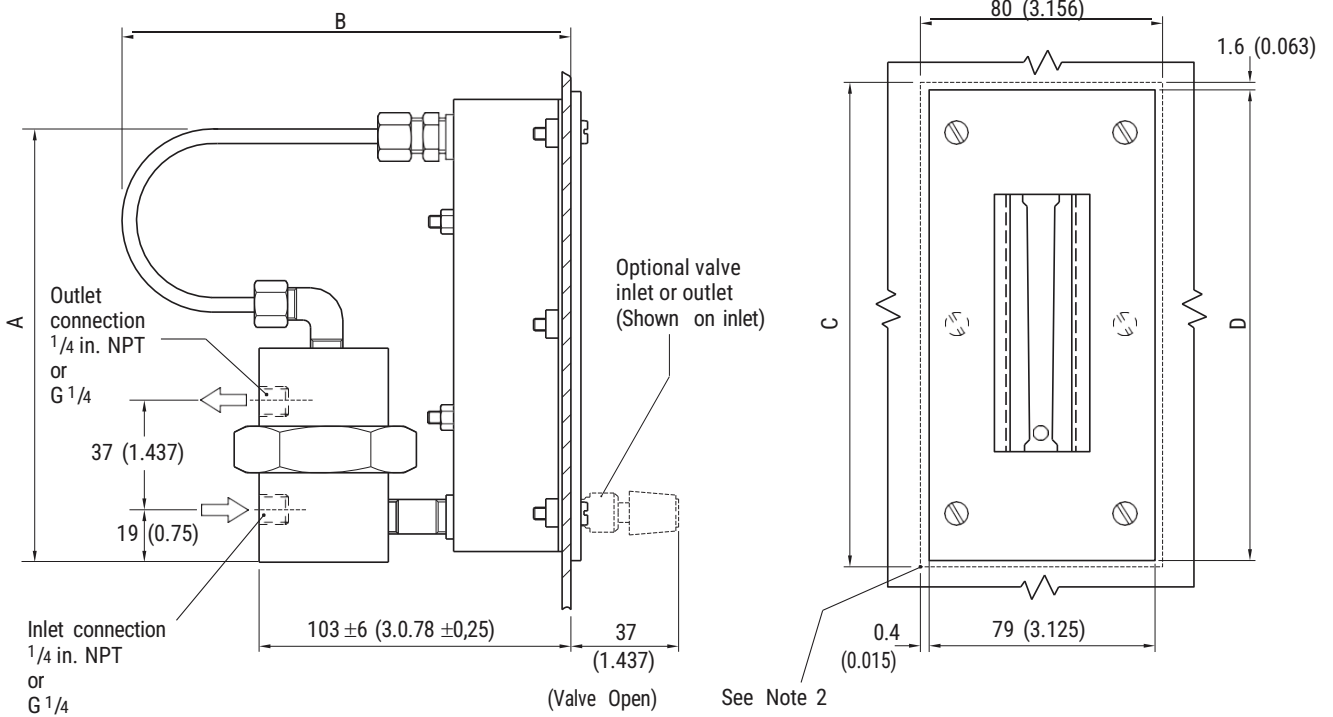

Dimensions

Scale Length		A		B		C		D	
in.	mm	in.	mm	in.	mm	in.	mm	in.	mm
1 1/2	38	5 7/8	149	5 7/8 ± 1/4	149 ± 6	5 3/32	129	4 31/32	126
3	76	5 7/8	149	5 7/8 ± 1/4	149 ± 6	6 5/16	160	6 3/16	157
5	127	10 1/4	260	4 21/32 ± 1/4	118 ± 6	10 3/4	273	10 5/8	270
10	254	14 11/16	373	4 21/32 ± 1/4	118 ± 6	15 3/16	386	15 1/16	383

Notes.

- 1) All dimensions are subject to a manufacturing tolerance of ± 3 mm (0.125 in.), unless otherwise specified.
- 2) Dotted line indicates rear of panel clearance requirements.
- 3) Panel hardware for 8 (0.312) max. panel thickness

Add full stop

Panel Cut-out for Panel-mounting

Dimensions in mm (in.)

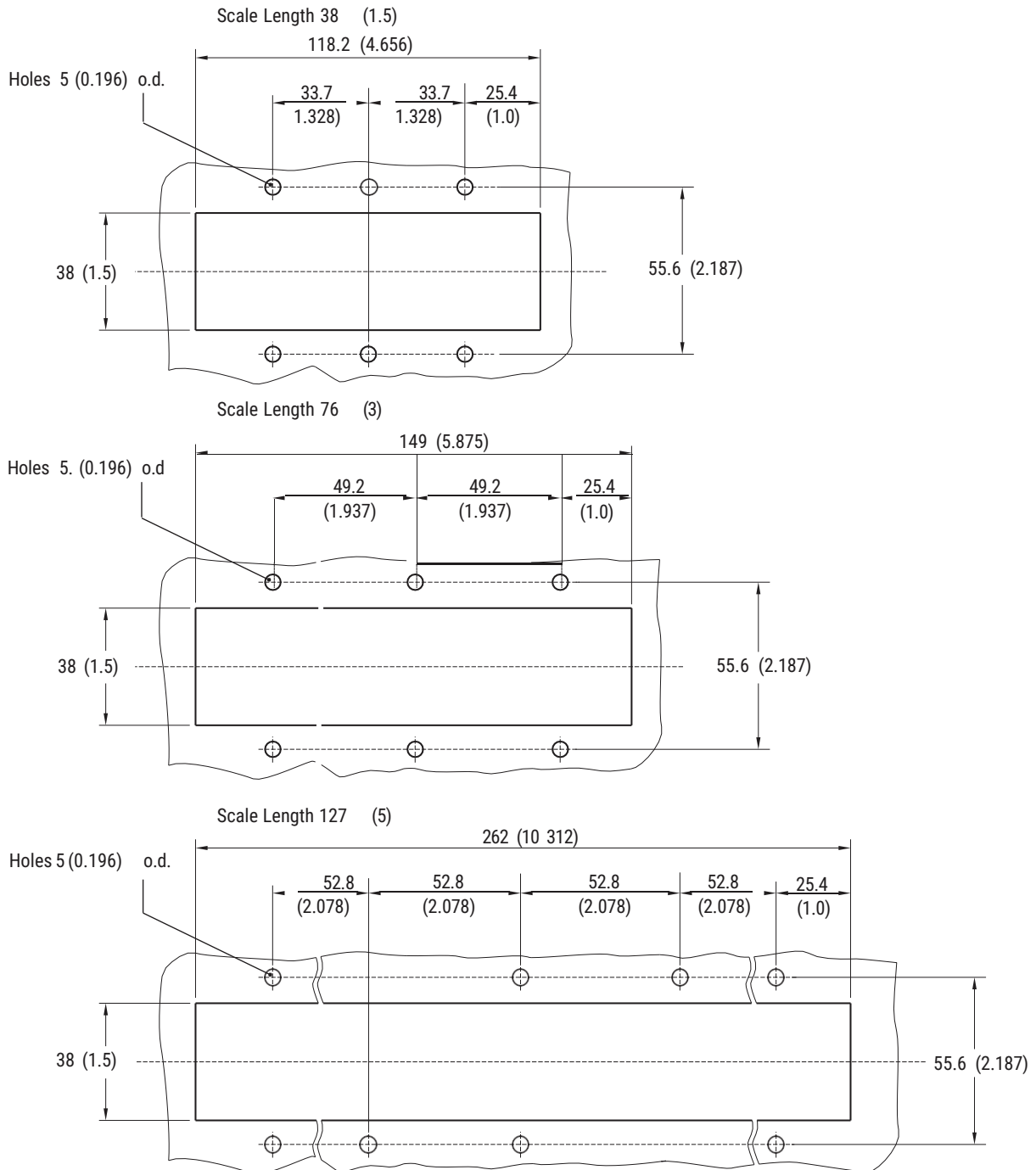

Ordering Information

Model Code	A6	X	X	X	X	X	X	X	X	X	X	X	X	X	X	X
Connection																
Horizontal	1															
Vertical	2															
Connection Type																
As regulator		2														
1/4 in. NTP		3														
G 1/4		4														
Special		5														
Tube Length																
3 in.				1												
5 in.				2												
1 1/2 in.				3												
Tube Diameter																
1/8 in.					B											
1/4 in.					C											
Tube / Float																
None						0	0									
Select from Tables on pages 3, 4 or 5						*	*									
Scale Type pages 3, 4, 5 or 6																
Without										0						
Direct reading										1						
dt/df ratio										2						
Percent										3						
Calibrated										5						
Materials																
Brass / Viton			A		Stainless steel / Buna					J						
Brass / Buna			B		Stainless steel / Ethylenepropylene					K						
Brass / Ethylenepropylene			C		Stainless steel / Kalrez					L						
Brass / Kalrez			D		Special					Z						
Stainless steel / Viton			I													
Valve																
Without Valve			A		DVGW Valve at Outlet, Low Capacity (Size 1.2)					S						
Valve at Outlet, Low Capacity (Size 1.2)			C		DVGW Valve at Outlet, Medium Capacity (Size 2.2)					Q						
Valve at Outlet, Medium Capacity (Size 2.2)			B		DVGW Valve at Outlet, High Capacity (Size 3.2)					U						
Valve at Outlet, High Capacity (Size 3.2)			E		DVGW Valve at Inlet, Low Capacity (Size 1.2)					I						
Valve at Inlet, Low Capacity (Size 1.2)			D		DVGW Valve at Inlet, Medium Capacity (Size 2.2)					R						
Valve at Inlet, Medium Capacity (Size 2.2)			N		DVGW Valve at Inlet, High Capacity (Size 3.2)					V						
Valve at Inlet, High Capacity (Size 3.2)			F													
Alarm (excluding amplifier)																
Without														A		
Min. alarm														B		
Max. alarm														C		
Min. & max. alarm														D		
Suitable for alarms (no sensors fitted)														E		
Regulator																
Without															0	
Standard capacity 1/4 in. NTP															1	
Standard capacity G 1/4															2	
High capacity 1/4 in. NTP															3	
High capacity G 1/4															4	
Mounting																
In-line																A
Wall																B
Rear panel																C
Front panel																D
Laboratory stand																E
Front panel + adaptor																F
Front panel + end cap																G
Front panel + end cap + adaptor																H
Design level																A
Certification																
ATEX II 2Gc T6 -T4 with Ring Sensor																A
ATEX II 2GDc T4 130 °C without Ring Sensor																D
None																S

Specification – Switching Amplifier

Switch amplifier

Amplifier	Supply Voltage	Channels
KFD2-SR2-Ex1.W	24 V DC	1
KFD2-SR2-Ex2.W	24 V DC	2
KFA5-SR2-Ex1.W	115 V AC	1
KFA5-SR2-Ex2.W	115 V AC	2
KFA6-SR2-Ex1.W	230 V AC	1
KFA6-SR2-Ex2.W	230 V AC	2

Output

Relay with potential-free changeover contacts.
Switching capacity max. 2 A at 250 V AC

Power consumption

Max. 1 W

Permissible ambient temperature

-20 to +60 °C (-4 to 140 °F)

Ex protection

Circuits in Zone 0/1/2 – EEx II (I) G D [EEx ai] IIC

$U_0 = 10.5 \text{ V}$

$I_0 = 13 \text{ mA}$

$P_0 = 34 \text{ mW}$

Certificate number

PTB 00 ATEX 2080

Protection class

IP20

Electrical connection

Terminals

Weight

0.15 kg (0.33 lb) approx.

Electrical Connections

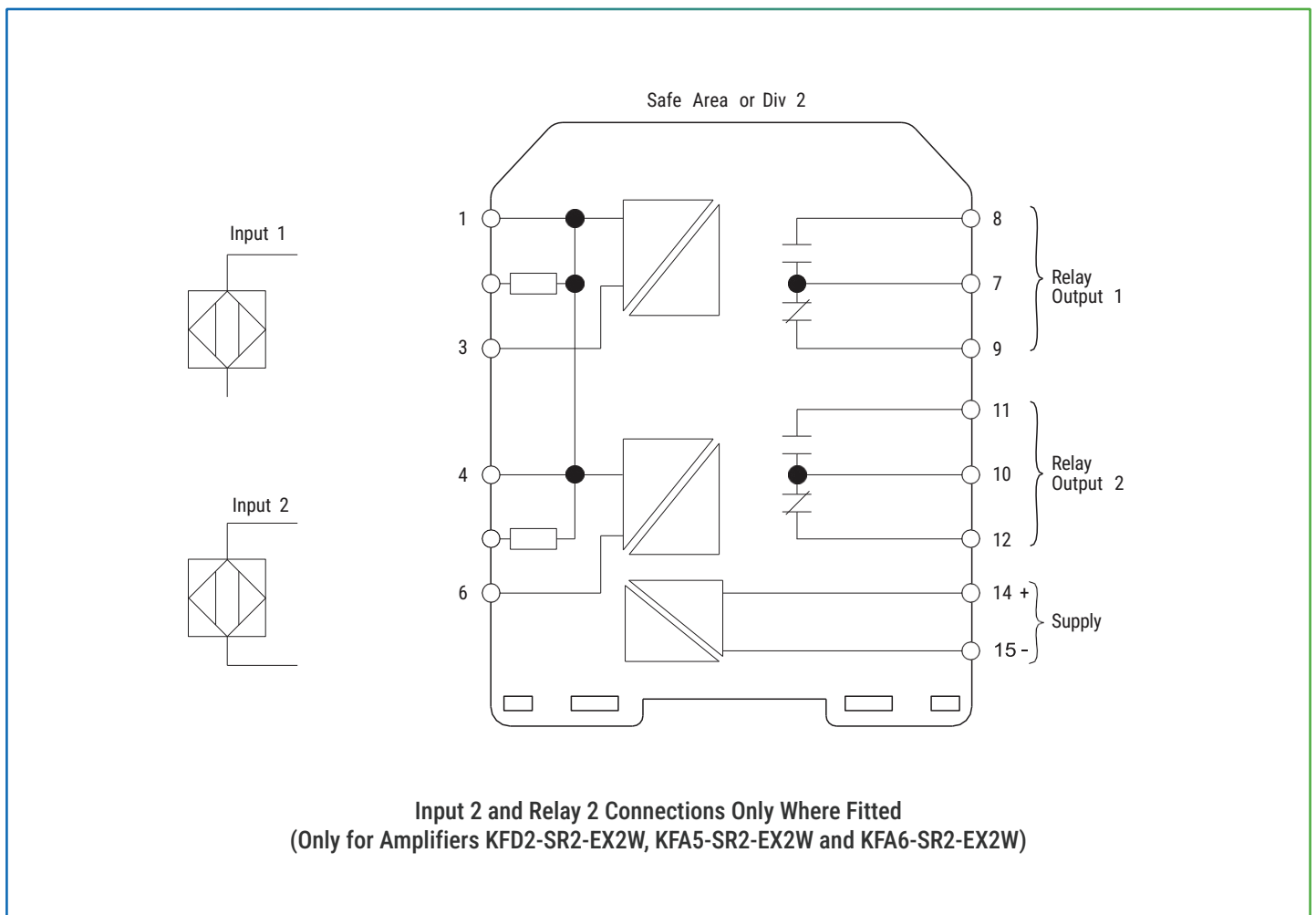

Overall Dimensions

Dimensions in mm (in.)

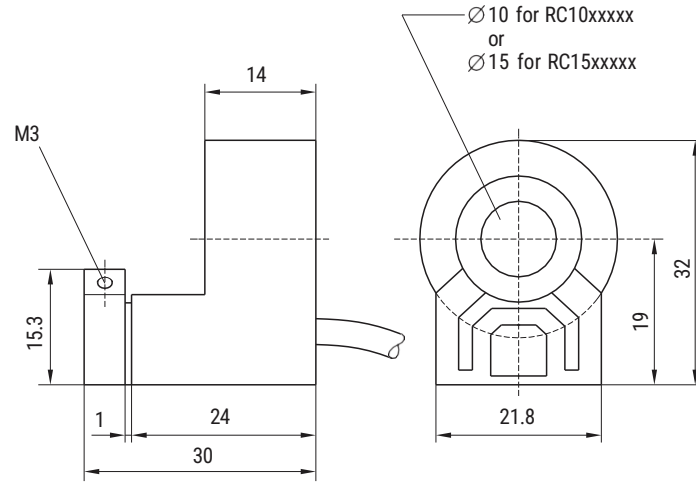

Ring Sensor

Dimensions in mm (in.)

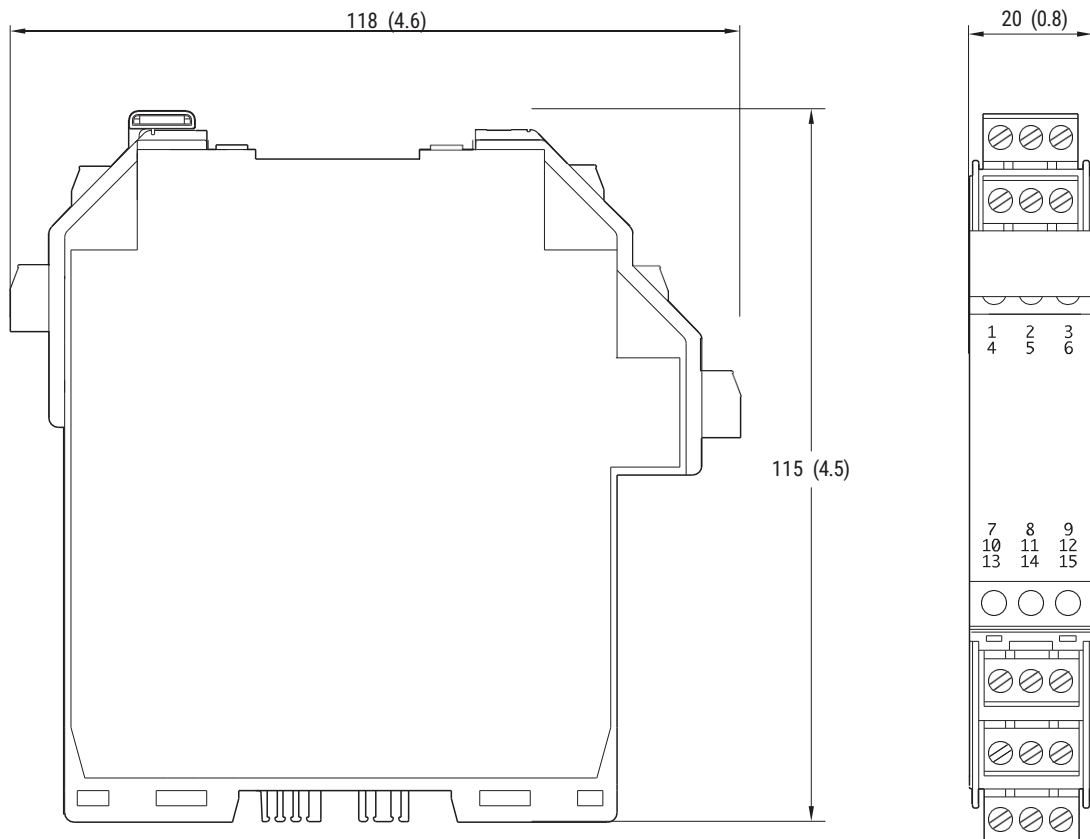

Switch Amplifier



McMenon Engineering Services Ltd
Salterbeck Trading Estate, Workington,
Cumbria, CA14 5DS, UK.

+44 (0)1946 830 611

sales@McMenon.com



www.mcmemon.com

OUR CERTIFICATIONS



Note:

We reserve the right to make technical changes or modify the contents of this document without prior notice. With regard to purchase orders, the agreed particulars shall prevail. MCMENON does not accept any responsibility whatsoever for potential errors or possible lack of information in this document.

We reserve all rights in this document and in the subject matter and illustrations contained therein. Any reproduction, disclosure to third parties or utilization of its contents in whole or in parts – is forbidden without prior written consent of MCMENON.